

VEGA 1500 Series RISER DOORS



For all bespoke requirements, our technical team will assist you to determine the correct specification and dimensions for your project.

+44(0) 1827 719 051
technical@profabaccess.com

Quick release, light weight, value engineered riser doors with pre-fitted locks and hinges for fast and simple installation

Profab Access' VEGA 1500 Series range of riser doors is designed, manufactured and tested to meet standards suitable for a wide range of non-fire rated market applications.

Single or double, quick release, light weight door configurations, including lock and frame options to suit finishing requirements, can be supplied.

» BENEFITS

- Fast and simple to install
- Quick release pivot hinge with retractable flush bolt
- Light weight door for easy handling
- Seamless aesthetic finish
- Single door (SD) or double door (DD) configurations
- Fully recyclable at end of life



SAFE ACCESS ALL AREAS

» DOOR CONFIGURATIONS

Construction

- Manufactured to order
- 1.2mm door and frame in electro-galvanised mild steel
- Fully welded 4 sided frame
- Light weight door: 17.5kg/m² with frame: 1.5kg/linear meter
- CNC manufactured in the UK to ISO 9001: 2015 and 14001: 2015

Performance

- Quick release hinge for fast and simple installation

Options

- 3 point lock (3PL) as standard or Euro profile cylinder high security lock option (3HS)
- Beaded frame or picture frame options to suit finishing requirements
- Fully powder coated matt RAL 9010, suitable for finishing on site or other RAL colours available on request

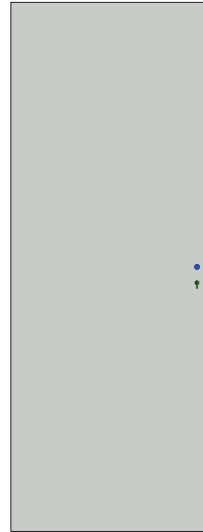

SD: SINGLE DOOR

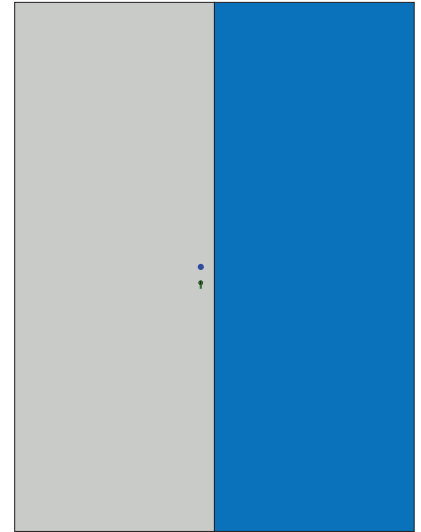

DD: DOUBLE DOOR

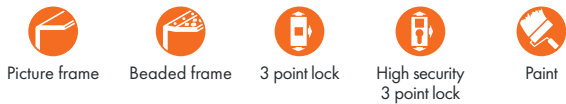

Picture frame

Beaded frame

3 point lock

High security
3 point lock

Paint



Hinge pin for easy positioning and door alignment



Quick release door mechanism operated by pull lever



Easy removal of the door from the frame



3 point locking mechanism including T-bar to unlatch and pull door leaf open

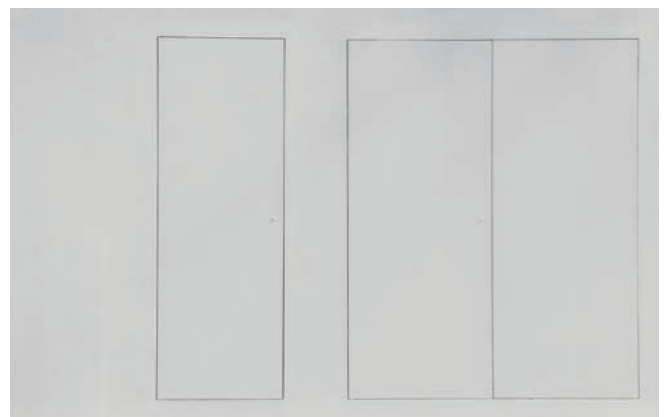

Lightweight door for easy handling with a seamless aesthetic finish

» MULTI-POINT LOCKING OPTIONS

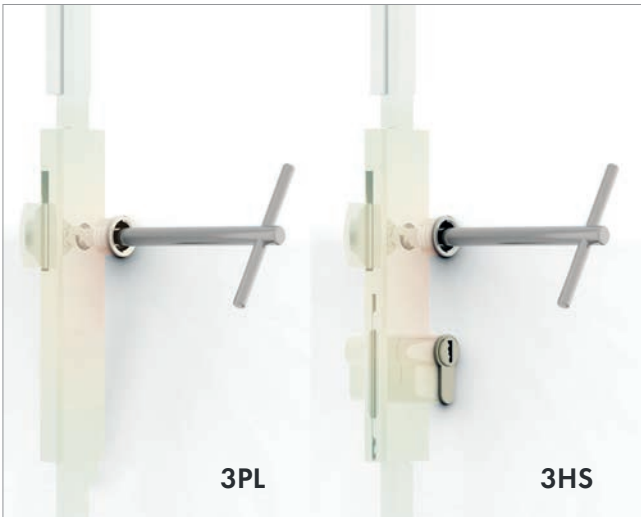

3PL: THREE POINT LOCKING

- i. T bar key: used to unlatch and pull door leaf open
- ii. Locking assembly: engages top, bottom and lock sides
- iii. White plastic collar and plug as standard (stainless steel collar optional)

3HS: THREE POINT HIGH SECURITY LOCKING

- i. T bar key: used to unlatch and pull door leaf open
- ii. Secondary locking
- iii. Euro profile cylinder lock
- iv. Locking assembly: engages top, bottom and lock sides
- v. White plastic collar and plug as standard (stainless steel collar optional)

» FRAME PROFILES

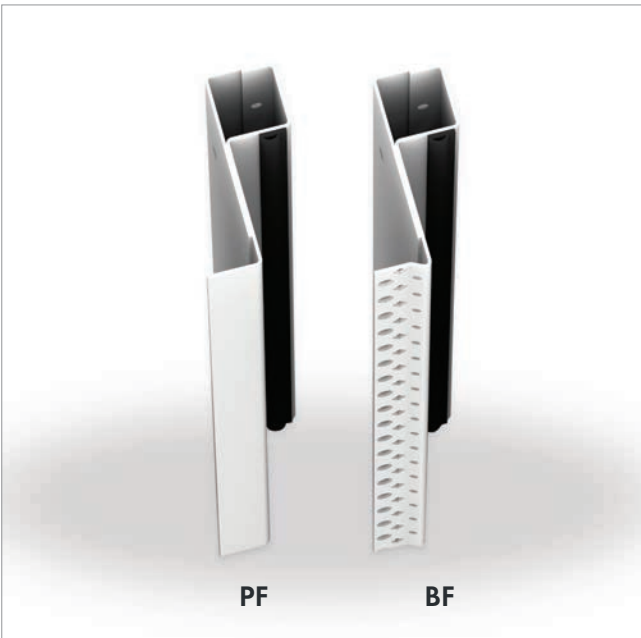

Choice of frame profiles to suit application

PF: PICTURE FRAME

Ideal for retro fitting/finished areas

BF: BEADED FRAME

Ideal for tape and jointing/skimming



Profab Access riser doors are virtually invisible, aesthetically enhancing the interior design of any building.

For more information about our full range of non-fire and fire rated riser doors visit:
www.profabaccess.com

Our in-house manufacturing enables us to offer full flexibility in product design for projects that need to meet specific design criteria



The Profab Access VEGA 1500 Series range of riser doors is available to download now as BIM objects for use in your current and future projects



» CAD DRAWINGS

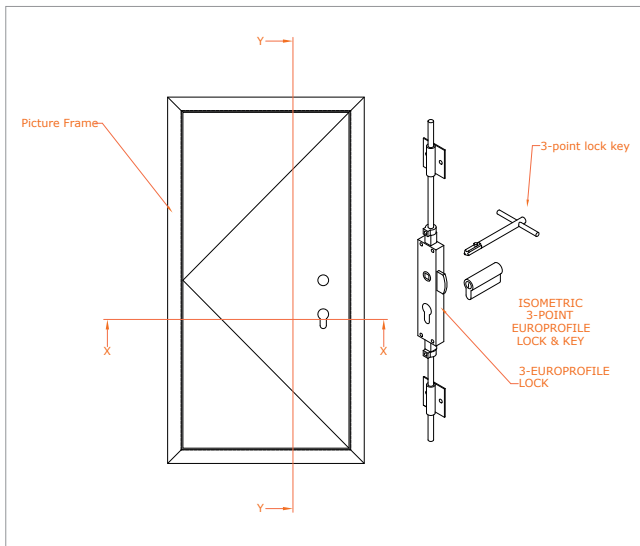

Non-fire rated, picture frame, 3 point high security locking, single door

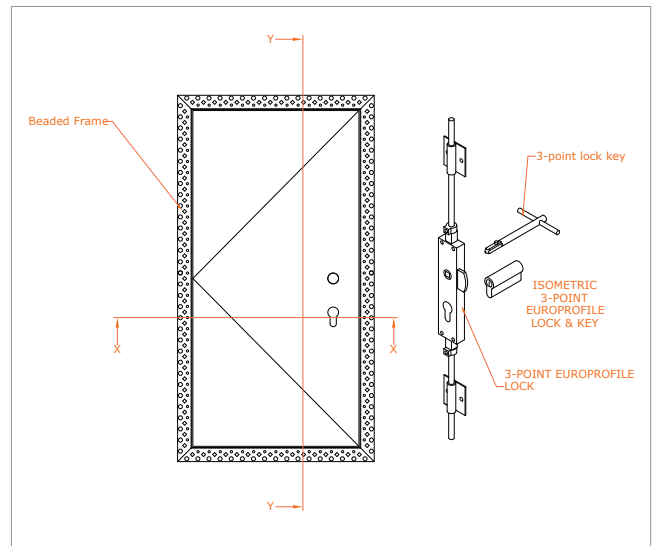

Non-fire rated, beaded frame, 3 point high security locking, single door

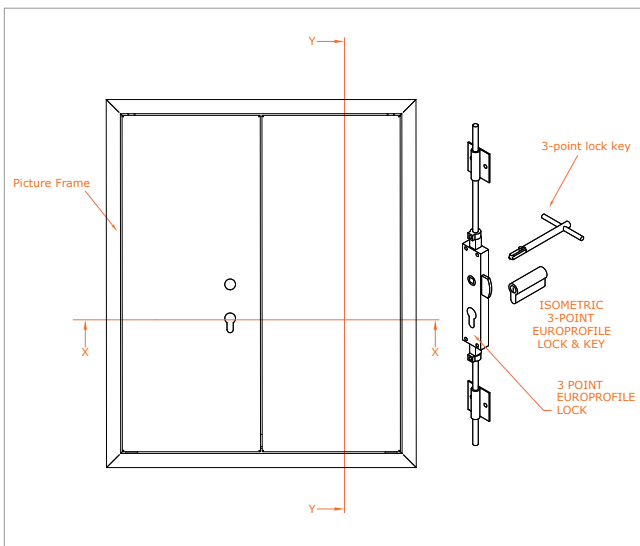

Non-fire rated, picture frame, 3 point high security locking, double door

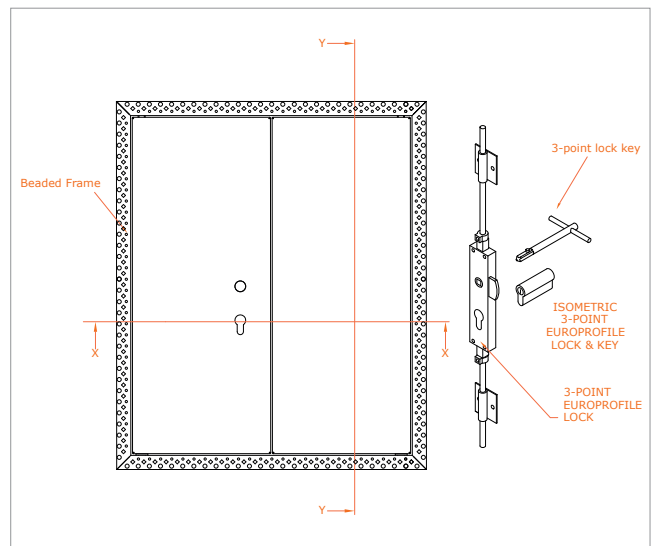

Non-fire rated, beaded frame, 3 point high security locking, double door

CAD files for all product variants are available – please contact: technical@profabaccess.com

All of our digital resources can be downloaded from: www.profabaccess.com

Profab Access reserve the right to amend any of our published information and specifications deemed necessary as part of our continuous product development and improvement policy, without prior notice.

» CONTACT US

Sales Enquiries

+44(0) 1827 718 222
sales@profabaccess.com

www.profabaccess.com

Technical Enquiries

+44(0) 1827 719 051
technical@profabaccess.com



Riversdale House
Units C-D Riversdale Road
Carlyon Road Industrial Estate
Atherstone
Warwickshire CV9 1FA
United Kingdom

 : profab-access-ltd

 : @accesspanels

 : profabaccesspanels

 : profabaccess.com



FS 668263 EMS 668264

